

Positive 7° Inserts for Aluminum Machining AS Chipformer

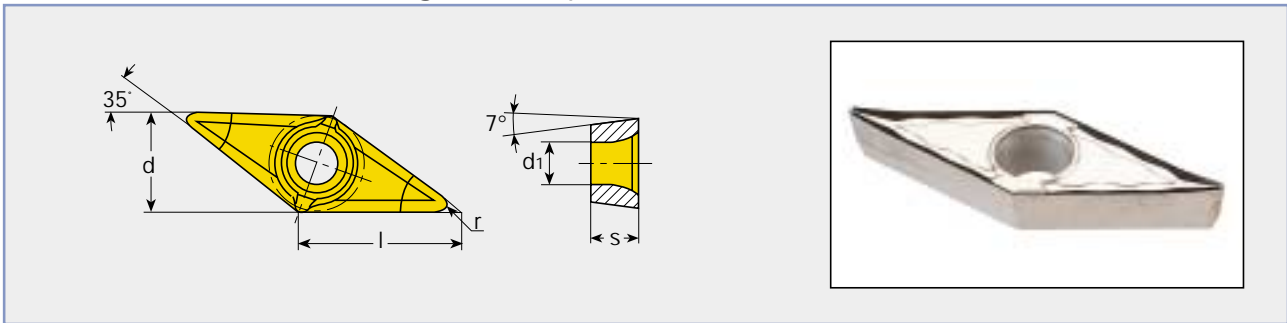

VCGT

Designation	l	d	s	d ₁	r
VCGT 110302-AS	11.1	6.35	3.18	2.9	0.2
VCGT 110304-AS					0.4
VCGT 160402-AS	16.6	9.52	4.76	4.4	0.2
VCGT 160404-AS					0.4
VCGT 160408-AS					0.8
VCGT 160412-AS					1.2
VCGT 220530-AS	22.1	12.7	5.56	5.5	3.0

For toolholders, see pages pages G44-46, G87-89.

For machining conditions, see pages G264-265.

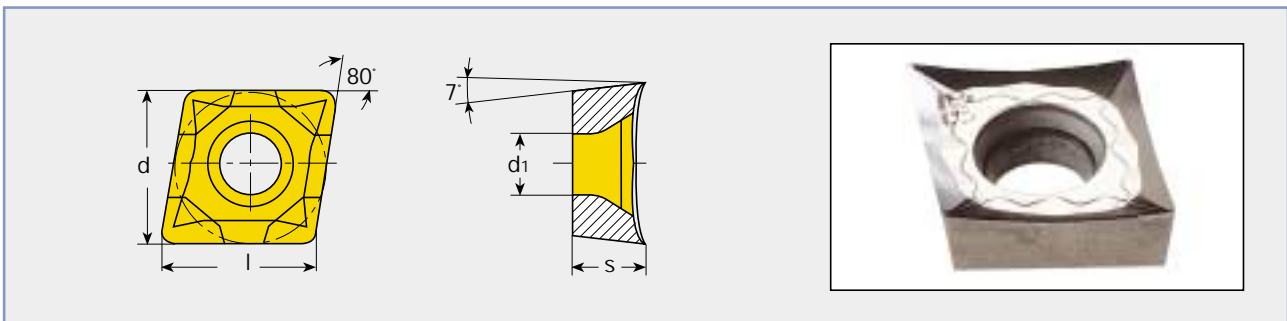

CCGT

Designation	l	d	s	d ₁	r
CCGT 060201-AS	6.4	6.35	2.38	2.8	0.1
CCGT 060202-AS	6.4	6.35	2.38	2.8	0.2
CCGT 060204-AS	6.4	6.35	2.38	2.8	0.4
CCGT 09T301-AS	9.7	9.525	3.97	4.4	0.1
CCGT 09T302-AS					0.2
CCGT 09T304-AS					0.4
CCGT 09T308-AS					0.8
CCGT 120402-AS	12.9	12.7	4.76	5.5	0.2
CCGT 120404-AS					0.4
CCGT 120408-AS					0.8

For toolholders, see pages G41, G83-84.

For machining conditions, see pages G264-265.