

CA 0608-R/L-LNET 12

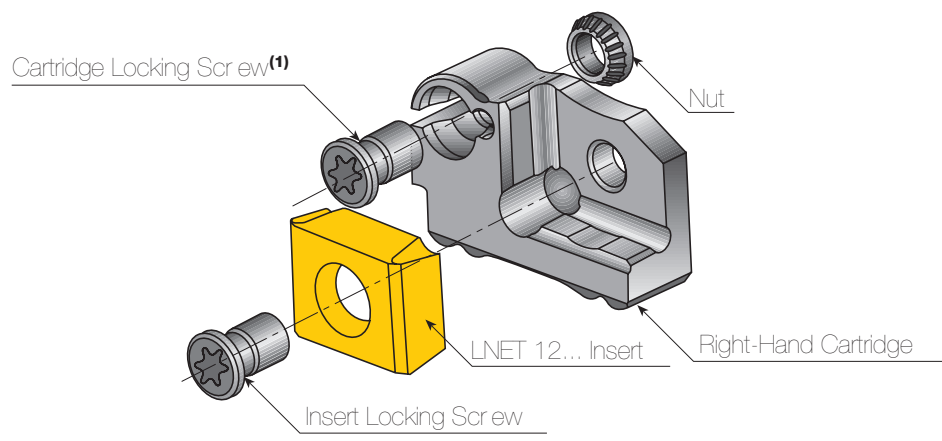

CA 08 10 R LN 12

CA - Cartridge

Adjustment Range

Minimum Width of Cut

Maximum Width of Cut

R.H. / L.H.

Type of Insert: LNET/R 12

Insert Size

Cartridge	Locking Screw	Nut	"ap" Width of Cut		Insert Designation	Insert Clamping Screw
			Min.	Max.		
CA 0608-R/L-LNET 12	SR 14-500-L4.5	NUT M4-2.2	6.00	6.50	LNET 1235...	SR 14-500/L4.9
			6.50	7.20	LNET 1240...	SR 14-500/L5.3
			7.00	8.20	LNET 1245..	SR 14-500/L5.9
CA 0810-R/L-LNET 12	SR 14-500-L6.1	NUT M4-2.2	8.00	8.70	LNET 1248..	SR 14-500/L6.7
			8.40	9.20	LNET 1250..	SR 14-500/L7.0
			8.90	10.5	LNET 1255..	SR 14-500/L7.5

Each insert size should be ordered with its appropriate screw. When changing insert size a new screw has to be ordered.

Keys:
 Torx TB-15/51
 Ratchet wrench key assembly
 (1)Tightening torque: 5 Nxm

Face Mill Arbor Hole Styles

	Da	E	d ₁	a	b
--	----	---	----------------	---	---

<p>Style A</p>	16	19	13.5	8.4	5.6
	22	20	18	10.4	6.5
	27	23	38	12.4	7.0

<p>Style B</p>	22	20	31	10.9	6.5
	27	25	38	12.4	7.0
	32	25	46	14.4	8.0
	40	33	56	16.4	9.0

	Da	E	d ₁	d ₂	d ₃	a	b
--	----	---	----------------	----------------	----------------	---	---

<p>Style C</p>	40	33	65	66.7	—	16.4	9.0
	60	38	—	—	—	25.7	14.0

<p>Style D</p>	60	38	—	101.6	177.8	25.7	14.0
-----------------------	----	----	---	-------	-------	------	------