

## Adapter Assembly on Square Shanks

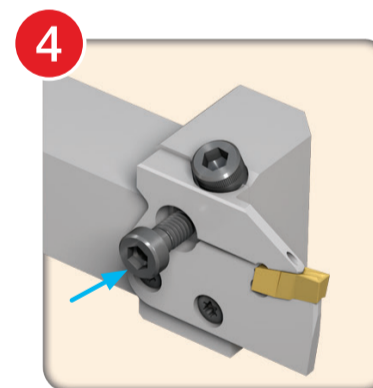
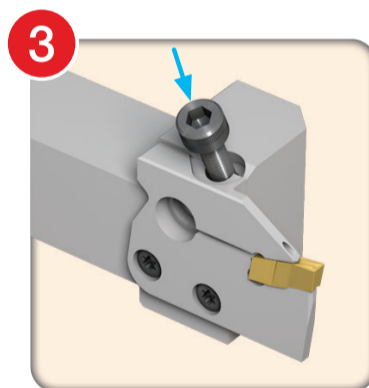
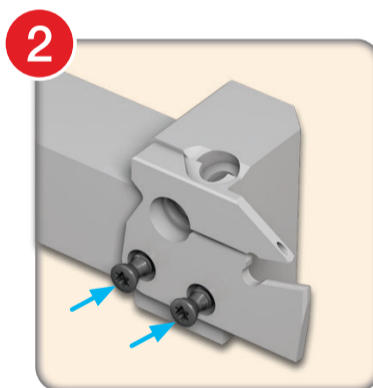
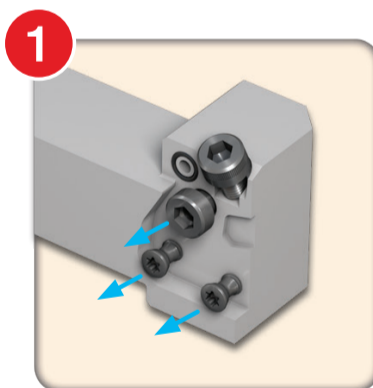
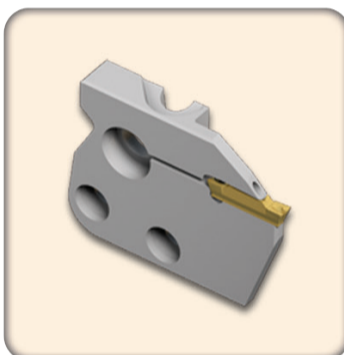
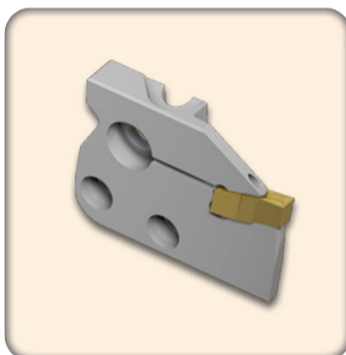

The tool is supplied with a long upper clamping screw which is inserted diagonally, two bottom clamping short screws, one middle (securing) screw and three sealing O-rings (two are spare).

- Unscrew all four screws and check that the O-ring is in place **(1)**
- Start by clamping the adapter with the two short bottom screws **(2)**
- Then place the insert into the pocket and clamp it with the long diagonal screw **(3)**
- Tighten the middle (securing) screw **(4)**

**Note:** The only purpose of the middle screw (SR M6X12DIN6912) is to secure the adapter against the O-ring and holder, in order to ensure a seal.