

When stepdown milling is performed by use of passes, the depth of cut per pass should not exceed the depth of cut as recommended in the ISCAR catalog.

Fig. 1- Generated profile for a depth of cut of up to 5mm

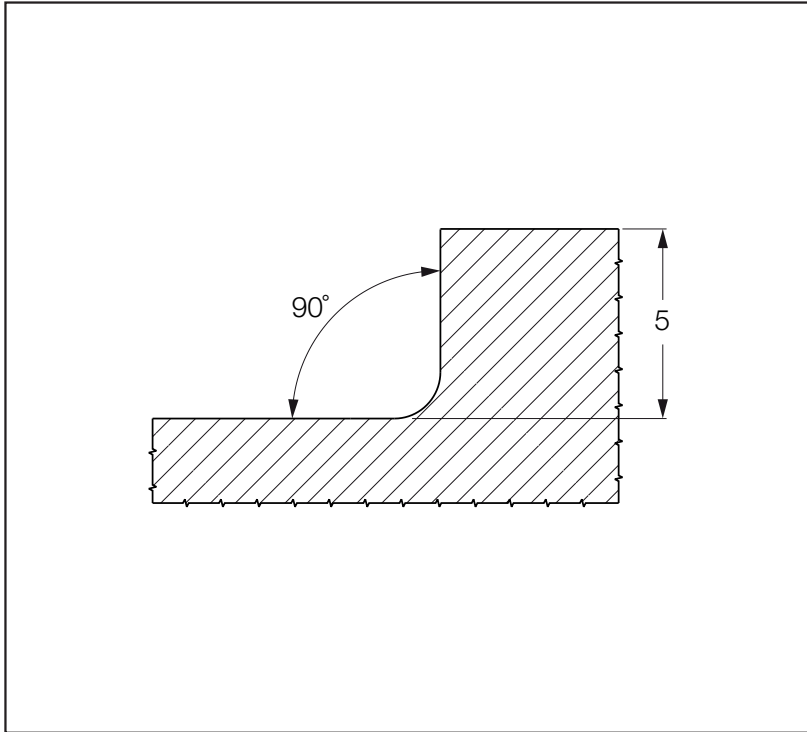

Fig. 2- Generated profile for a depth of cut in stepdown milling

