

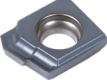





Spare Parts							
Tool Diameter		Insert			Guide Pad		
Min	Max	Insert	Screw	Wrench	GP X 2pcs	Screw X 2pcs	Wrench
10.00	10.99	ZSGT 060204R-DT	SR-M2.5X0.35L3.8	T-7/5	GPS-04-16-045-DC	CSTB-2	T-6/5
11.00	11.80				GPS-04-16-050-DC		
11.81	11.99	LOGT 060204R-DT	SR 10503833L040				

Recommended tightening torque: SR-M2.5X0.35L3.8=1.1 Nm, SR 10503833L040=1.3 Nm, CSTB-2=0.6 Nm

Universal Marking for Deep Drilling Tools

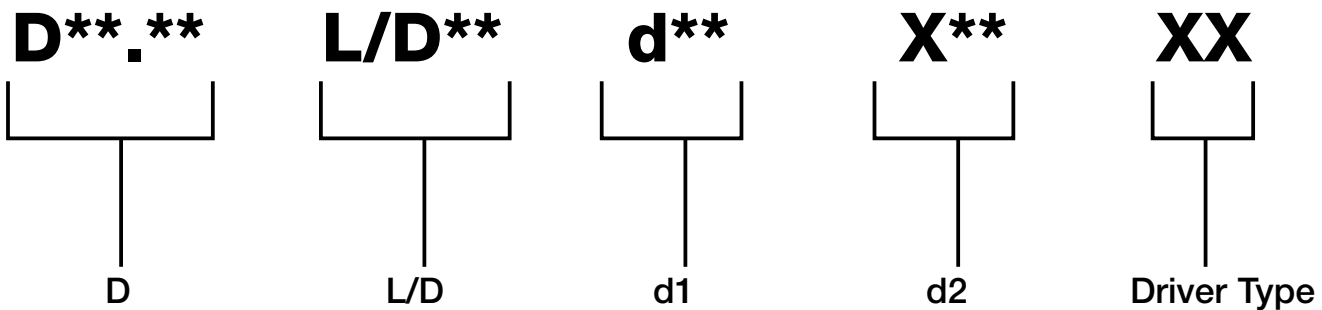
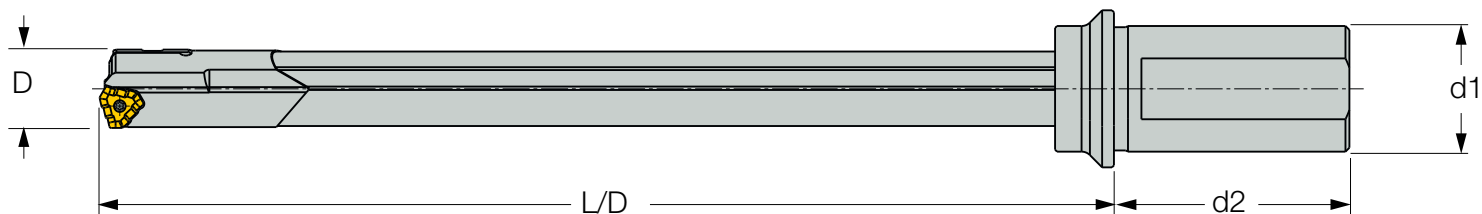

Example:

Metric: D14.00 L/D15 d25X56M

Inch: D0.551 L/D15 d0.984X2.205M

***** [Lot no.]