

Slot Milling Cutters

Tolerances

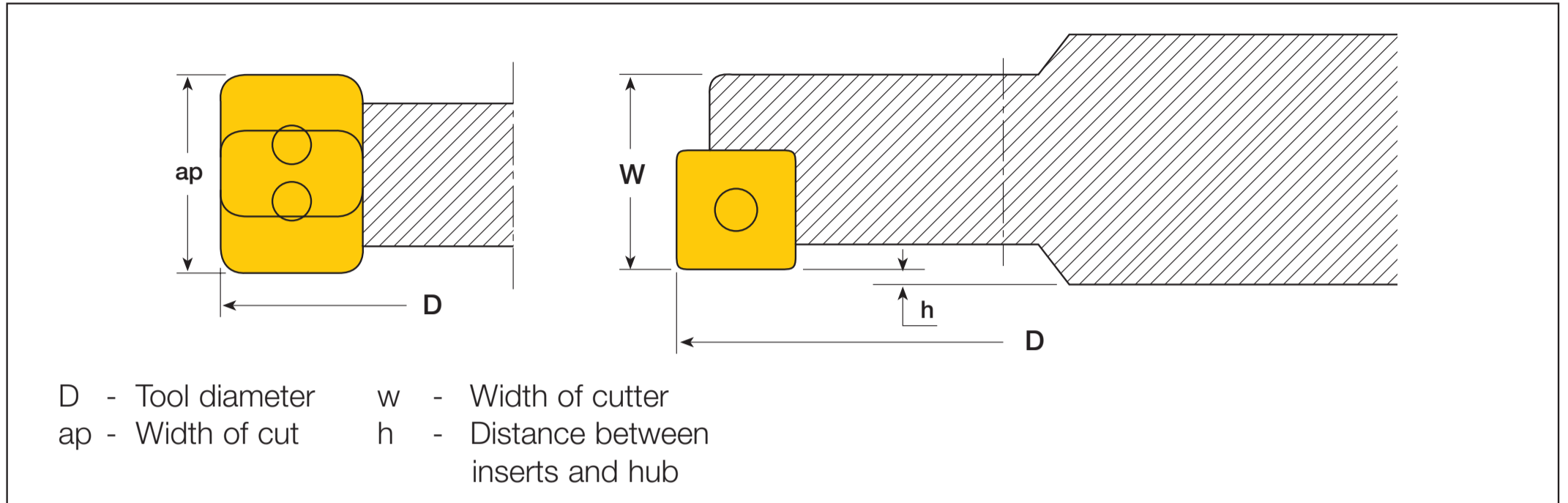

Inserts / Tool Designation	D	ap	w	h
	FDN • FST FSB • SDN • SSB	SDN • FDN	SSB • FST • FSB	SSB
ADKT 1505-PDR-HM ADKT 1505-PDL-HM	±0.20	+0.02 -0.12	±0.15	±0.03
All others	±0.20	+0.1 -0.2	±0.3	±0.08
LNET 12... with Integral Tools	±0.1	±0.05		
LNMT 1506... HT LNHT 1506... HT Tools with Cartridges	±0.2	±0.03		
LNKX 1506... with Integral Tools	±0.2			±0.03

Maximum Mismatch Values

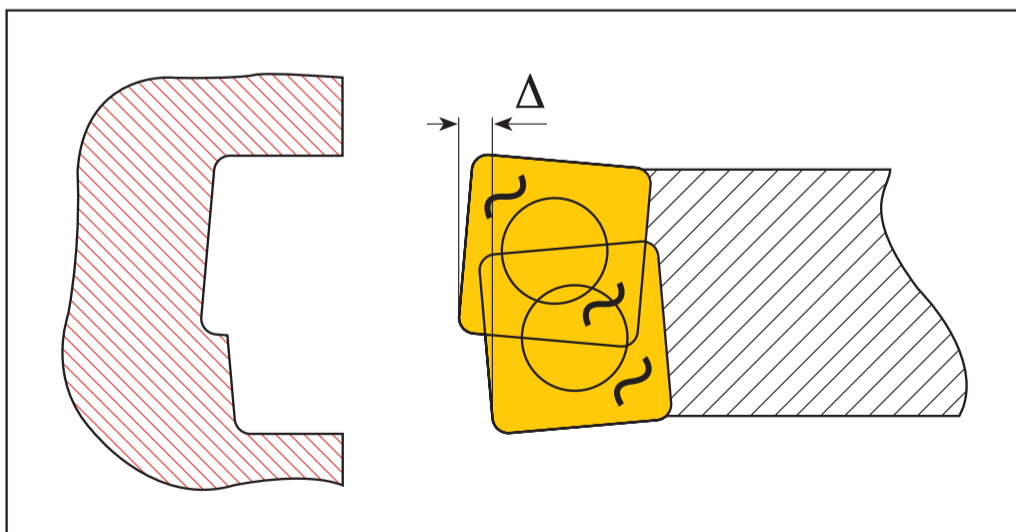

Insert	XOMT 06	SOMT 06	XPMT 10	QPMT 10	QDMT 10	QDCT 12	ADKT 15	LNET 12 ⁽¹⁾	LNMT...H LNHT...HT ⁽²⁾
Δ	0.12	0.15	0.14	0.15	0.09	0.07	0.14	0.07	0.09

⁽¹⁾ Integral tools

⁽²⁾ Tools with cartridges

All of the dimensions according to standard inserts.